



General Certificate of Secondary Education

Centre Number

--	--	--	--	--

Candidate Number

--	--	--	--	--

Physics

Unit 2

Foundation Tier



[GPY21]

GPY21

Assessment

TIME

1 hour 15 minutes.

Assessment Level of Control:

Tick the relevant box (✓)

Controlled Conditions	
Other	

INSTRUCTIONS TO CANDIDATES

Write your Centre Number and Candidate Number in the spaces provided at the top of this page.

You must answer the questions in the spaces provided.

Do not write outside the boxed area on each page or on blank pages.

Complete in black ink only. **Do not write with a gel pen.**

Answer **all five** questions.

INFORMATION FOR CANDIDATES

The total mark for this paper is 80.

Figures in brackets printed down the right-hand side of pages indicate the marks awarded to each question or part question.

Quality of written communication will be assessed in question **1(d)**.



1 (a) A musical instrument emits a sound wave of frequency 256 Hz.

(i) What type of wave is a sound wave? _____ [1]

(ii) How many sound waves are produced every second?
_____ [1]

(b) The apparatus shown below is used to produce waves in a string. The vibrator moves one end of the string up and down vertically.

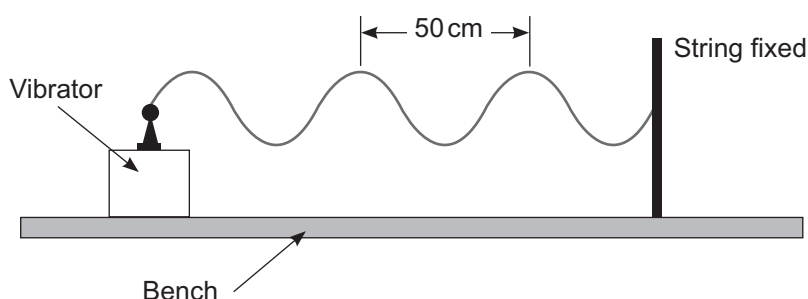

Source: Chief Examiner

(i) What is the wavelength of the waves produced on the string?

Wavelength = _____ cm [1]

(ii) The frequency of the waves is 40 Hz. Using your answer to (b)(i) calculate the speed of the waves. **Include the unit for speed with your answer.**

Show clearly your calculation, starting with the equation you plan to use to get your answer.

Speed = _____ [4]



(c) The diagram below shows water waves passing from deep water into shallow water.

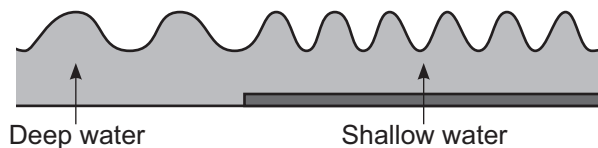

Source: Chief Examiner

The table below lists three quantities associated with the water waves. Complete the table by placing a tick (✓) in the box that describes what happens, if anything, to each quantity as the water waves move from deep water into the shallow water.

	Increases	Decreases	Stays the same
Speed			
Wavelength			
Frequency			

[3]

[Turn over



(d) Echo sounding uses ultrasound waves to measure the depth of an ocean. Describe, in detail, how this process is carried out.

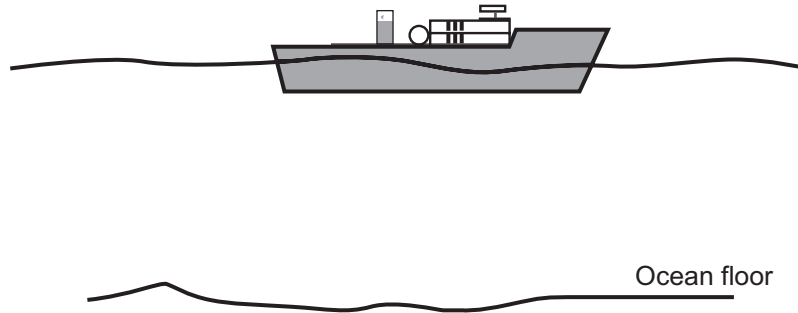

Source: Chief Examiner

In your description you should state the following:

- the difference between sound waves and ultrasound waves;
- what happens to the ultrasound wave when it reaches the ocean floor;
- why the ultrasound is emitted as short pulses rather than continuously;
- what measurement is made;
- what property of the ultrasound is needed for the calculation of the depth of an ocean;
- the calculation used to determine the depth of the ocean.

In this question you will be assessed on your written communication skills including the use of specialist science terms.

Write your answers in the spaces below and on the opposite page.

Difference between sound and ultrasound





What happens to the ultrasound at the ocean floor

Why short pulses of ultrasound are emitted

Measurement made

Property of the ultrasound wave needed

Calculation used

[6]

[Turn over



- (e) The diagram below shows the different regions of the electromagnetic spectrum. The diagram is incomplete.

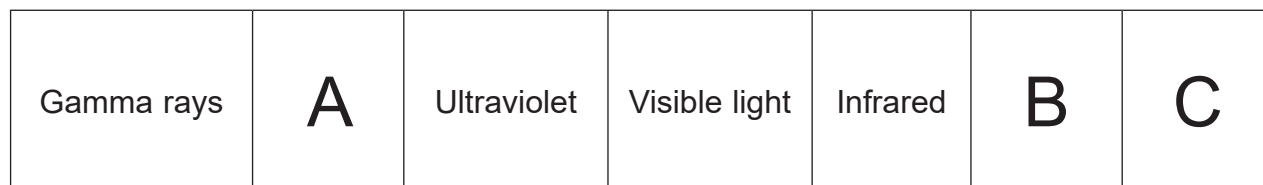

Increasing wavelength \longrightarrow

- (i) Name the electromagnetic waves missing from boxes A, B and C.

A _____

B _____

C _____

[3]

- (ii) Use the information given in the diagram to explain why gamma rays are likely to cause most damage to the human body.

[1]





BLANK PAGE

DO NOT WRITE ON THIS PAGE

(Questions continue overleaf)

12409

[Turn over



24GPY2107

2 (a) The image in a plane mirror is virtual.

(i) What is a virtual image?

_____ [1]

(ii) State **three other** properties of the image in a plane mirror.

1. _____
2. _____
3. _____ [3]

(b) The diagram shows a ray of light as it refracts at an air–glass boundary.

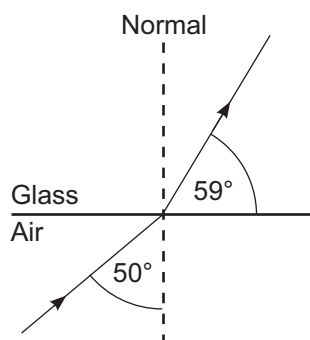

(i) What size is the angle of incidence?

Angle of incidence = _____ ° [1]

(ii) What size is the angle of refraction?

Angle of refraction = _____ ° [1]

(iii) What, if anything, happens to the speed of light as it passes from air into glass?

_____ [1]



(iv) Which one of the graphs below shows best how the angle of refraction in glass changes as the angle of incidence is increased?

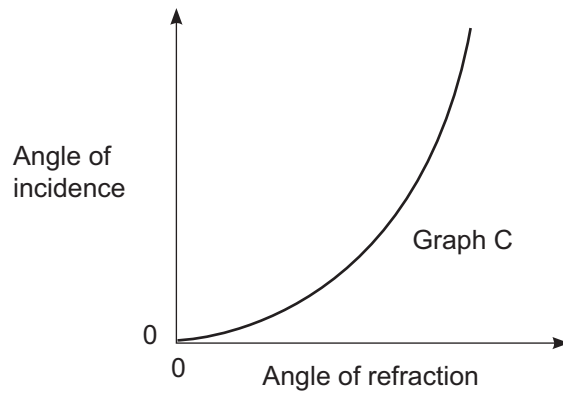
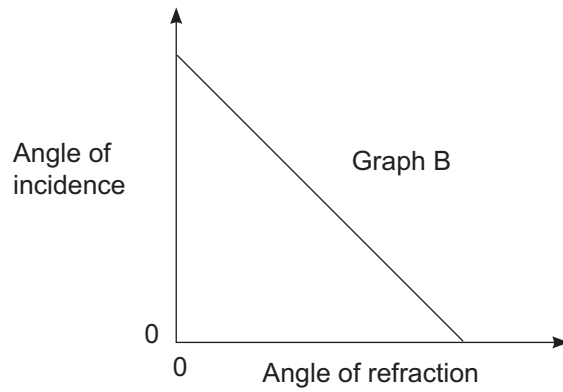
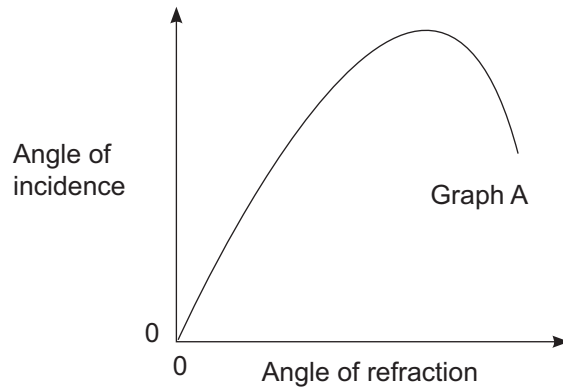

Graph _____ [1]

[Turn over



(c) John can see distant objects clearly, but finds that near objects, about 25 cm away from his eye, appear blurred.

(i) What name is given to this defect of vision? _____ [1]

(ii) What is the main cause of this defect of vision?

_____ [1]

(iii) What type of lens is used to correct this defect of vision? _____ [1]

(iv) On the diagram below show what happens to two rays of light from a near object when they enter John's unaided eye.

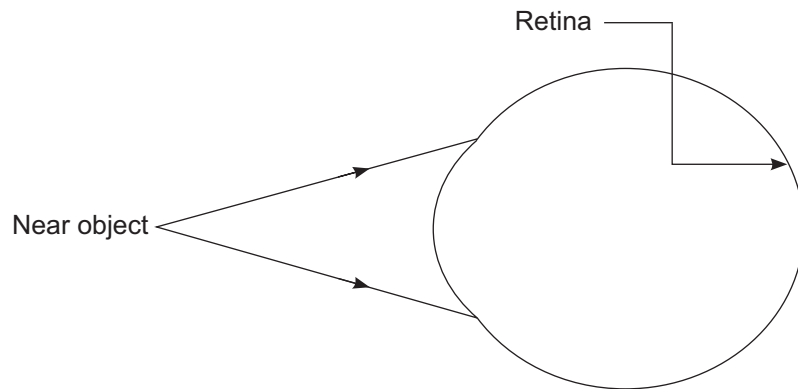

[2]

(v) On the diagram below show how the correcting lens changes the paths of the rays of light to enable John to see near objects clearly.

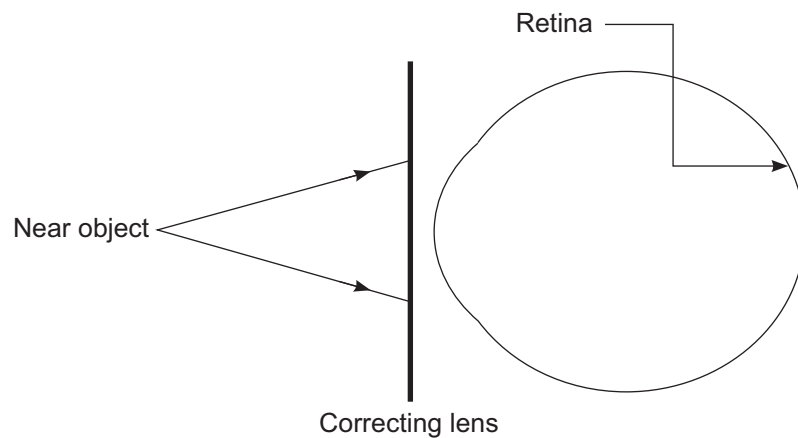

[2]



- (d) A convex lens has a focal length of 2 cm.
An object, O, placed 5 cm away from the lens forms a real image.

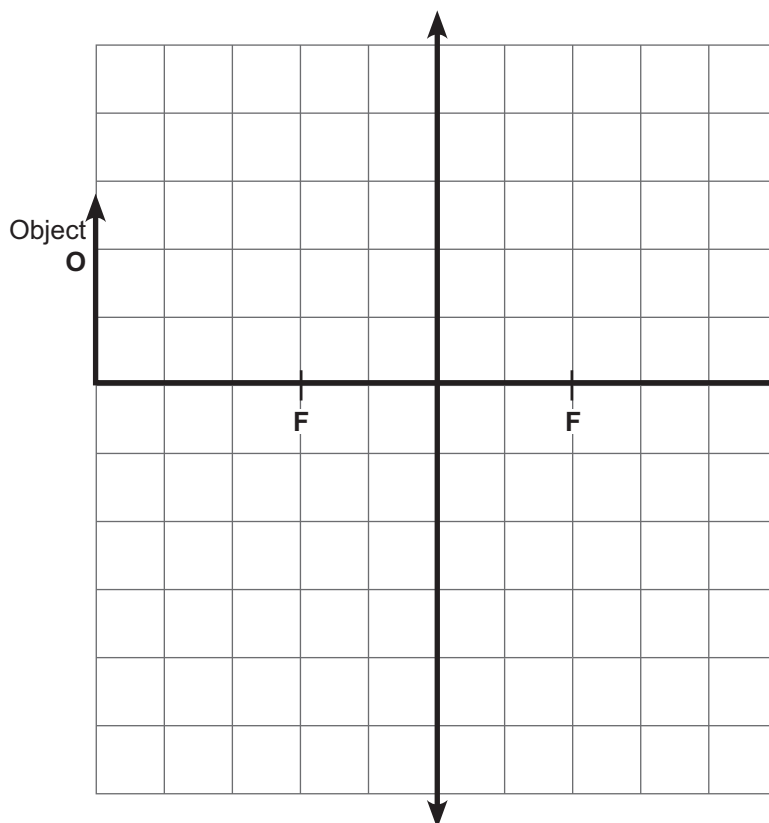

- (i) Draw two rays, both starting from the top of the object, to show where the real image is formed. Draw arrows on your rays. [2]

- (ii) Draw the image formed and label it with the letter I. [1]

- (iii) Which of the following best describes the real image?
Tick (✓) the appropriate boxes to indicate your responses.

- Erect
- Inverted
- Bigger than object
- Smaller than object
- Same size as object

[2]

[Turn over



- 3 (a) The circuit below shows two resistors, R_1 and R_2 , connected to a power supply.

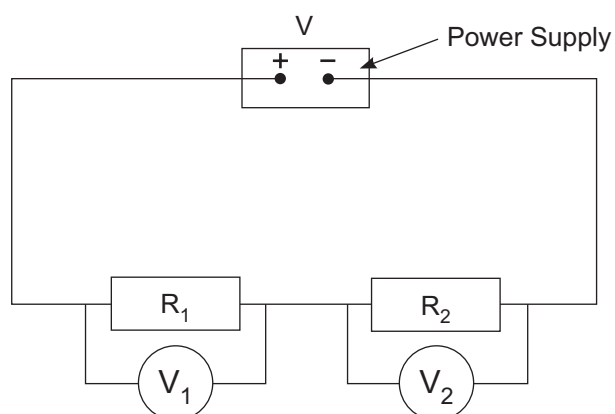

The voltmeter V_1 reads 2 V and the voltmeter V_2 reads 4 V.

- (i) Calculate the voltage V provided by the power supply.

Power supply voltage $V =$ _____ V [1]

- (ii) The current flowing through R_1 is 0.4 A.
What is the current flowing through R_2 ?

Current through $R_2 =$ _____ A [1]



- (b) The circuit diagram below shows a battery of four cells supplying current to a lamp.

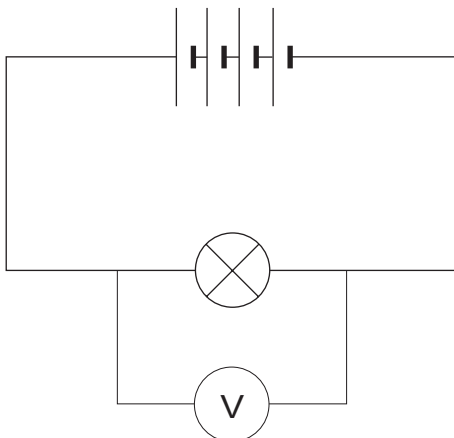

- (i) Each cell provides a voltage of 1.5 V.
What would the voltmeter read?

Voltmeter reading = _____ V [1]

- (ii) When the lamp is lit a current of 2 A flows through it.
Calculate the resistance of the lamp when it is lit.
Show clearly your calculation, starting with the equation you plan to use to get your answer.

Resistance = _____ Ω [3]

- (iii) Calculate the charge that flows through the lamp when it is lit for a time of 30 s.
Show clearly your calculation, starting with the equation you plan to use to get your answer.

Charge = _____ C [3]

[Turn over



- (c) The diagram below shows some of the details from a label on a household electric kettle.

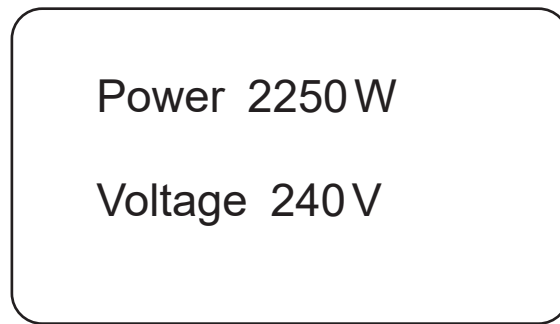

- (i) Using the information from the label above, calculate the current in the kettle when in normal use.
Show clearly your calculation, starting with the equation you plan to use to get your answer.

Current = _____ A [3]

- (ii) Select a suitable fuse for the plug attached to the kettle.
The fuses available to you are rated 1A, 3A, 5A and 13A.

Fuse = _____ A [1]



(d) The diagram below shows an incomplete circuit using a two-way switch.

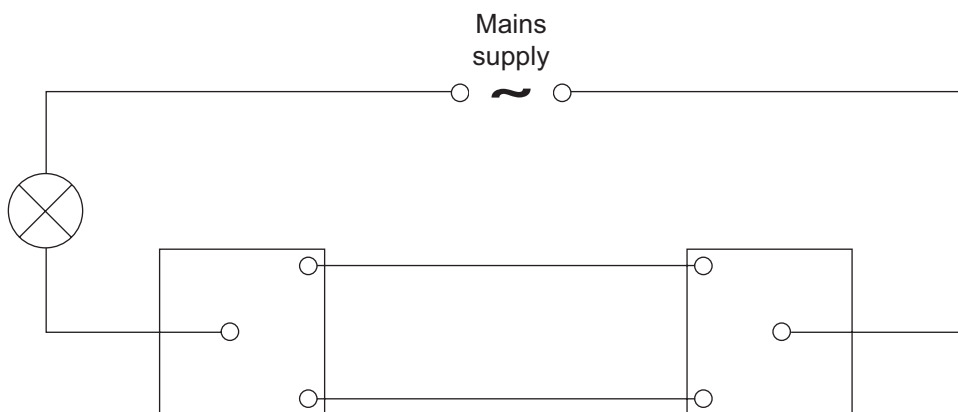

(i) Complete the circuit diagram to show the lamp lit. [1]

(ii) What is the advantage of a two-way switch over a one-way switch?

[1]

[Turn over



(e) Electricity companies bill their customers for the number of units they use. The correct name for a unit is the kilowatt-hour (kWh).

(i) What is the kilowatt-hour a measurement of?
Select your answer from:

Voltage Energy Current Power Charge

Kilowatt-hour is a measure of _____ [1]

(ii) The cost of a unit of electricity is 17p.
Calculate the cost of operating a 2.2 kW electric fire for 1.5 hours.
Show clearly your calculation, starting with the equation you plan to use to get your answer.

Cost = _____ p [3]



- (f) The photograph shows the three pin plug of the charger for a mobile phone. The pin which normally acts as the earth pin is made of plastic.

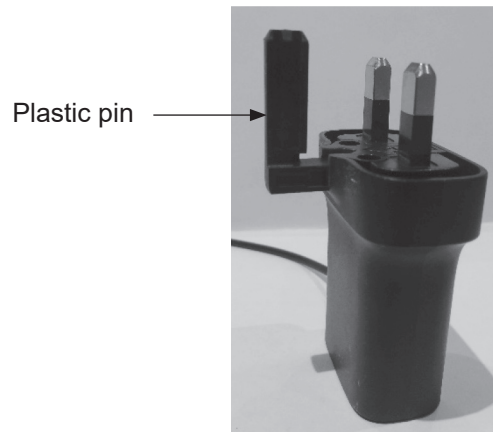

Source: Chief Examiner

State the method used in this case to protect the user.

[1]



- 4 (a) When a current is passed through a coil of wire, a magnetic field is created around the coil.

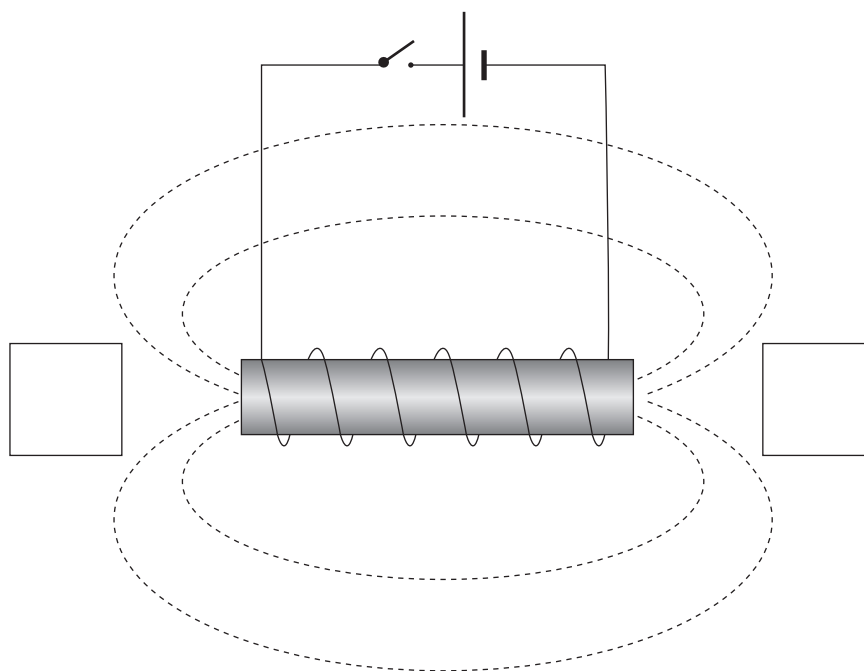

Source: Chief Examiner

- (i) On the diagram label the north pole (N) and south pole (S) of the magnetic field created. Write your answers in the boxes provided

[1]

- (ii) On the diagram mark the direction of the magnetic field lines.

[1]



(b) The diagram below shows three waveforms seen on the screen of a cathode ray oscilloscope (CRO).

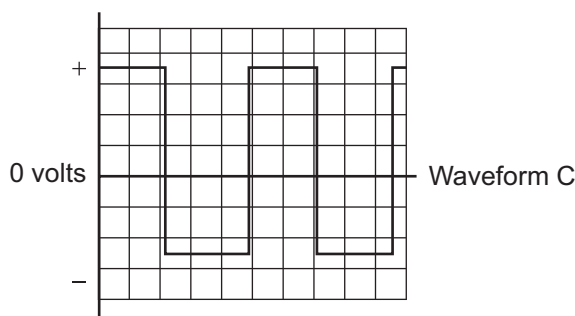
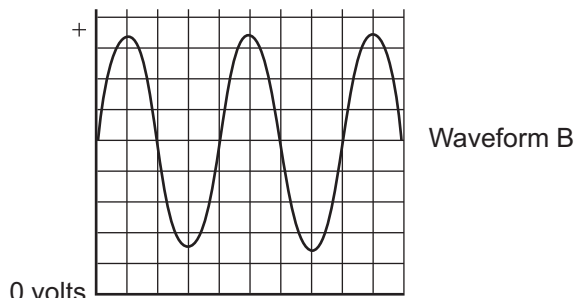
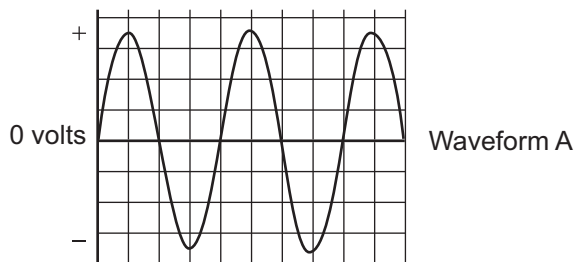

Source: Chief Examiner

(i) Which waveform does **not** show an alternating voltage? _____ [1]

(ii) Explain your answer _____

_____ [1]

[Turn over



(c) Electromagnetic induction can be demonstrated using two coils of wire as shown below.

Coil A is in a circuit consisting of a cell and a switch.

Coil B is connected to a sensitive centre-zero ammeter.

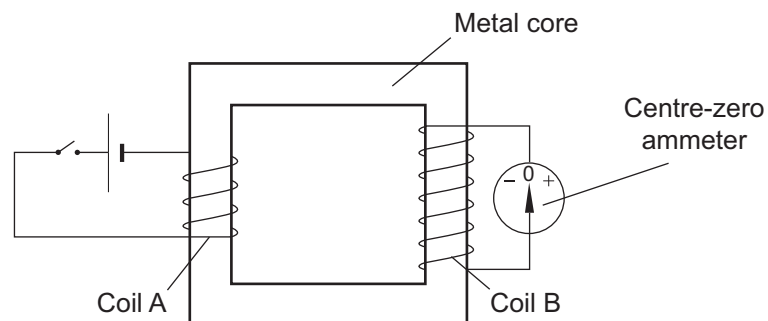

Source: Chief Examiner

(i) The metal core is designed to increase the strength of the magnetic field. What metal is it made of?

_____ [1]



(ii) Below is a list of possible observations that describes the movement of the pointer on the centre-zero ammeter when the various actions are carried out in the order step 1, step 2, step 3 and finally step 4.

- A. Momentary deflection**
- B. Pointer is deflected and does not return to zero**
- C. No deflection**
- D. Pointer moves to one side then to the other continuously**

For each of the actions described below, write the letter that corresponds to the observation.

	Action	Observation (A to D)
Step 1	The switch in the circuit connected to coil A is closed.	
Step 2	The switch in the circuit connected to coil A remains closed.	
Step 3	The switch in the circuit connected to coil A is now opened.	
Step 4	The switch in the circuit connected to coil A is opened and closed repeatedly.	

[4]

[Turn over



- 5 (a) Below is a list of statements about the Big Bang. Only two statements are correct. Tick (✓) those that are correct.

The Big Bang occurred 14 million years ago	
Evidence for the Big Bang comes from Red Shift	
The Big Bang marked the formation of our Solar System	
As a result of the Big Bang space is expanding	

[2]

- (b) The diagram below shows our Solar System.

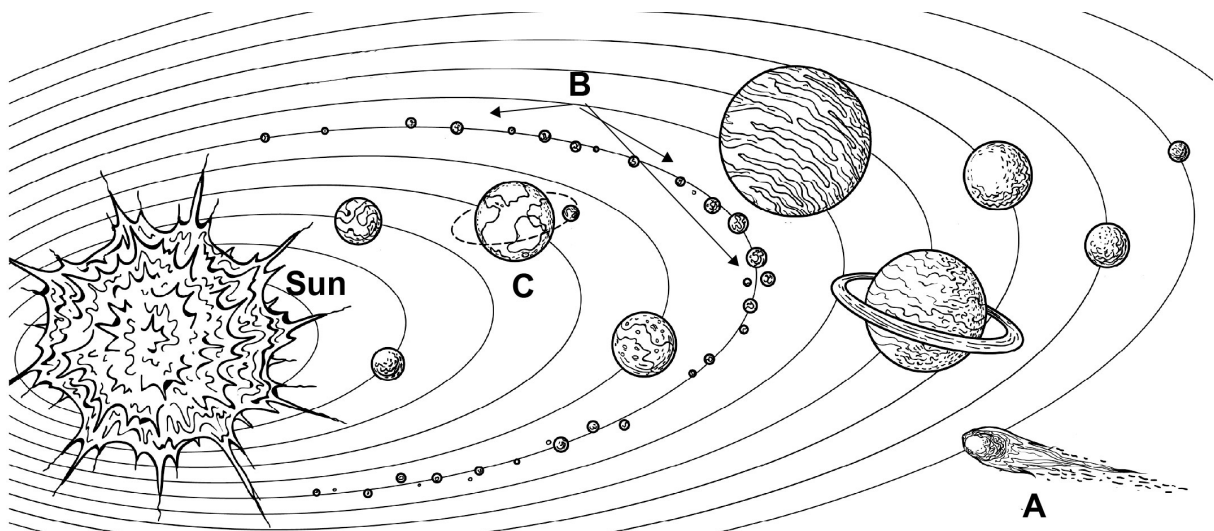

© Getty Images

- (i) Name the parts labelled A, B and C.

A = _____ B = _____ C = _____

[3]

- (ii) What force keeps the planets of our Solar System in orbit around the Sun?

_____ [1]



(c) Exoplanets are those which lie outside our Solar System. Astronomers are currently looking for exoplanets whose atmospheres contain oxygen, because oxygen is essential for life.

(i) How can an astronomer tell if a planet's atmosphere contains oxygen?

[1]

(ii) Even if such an exoplanet could be found, visiting it with unmanned probes in the near future is extremely unlikely. Suggest why this is so.

[1]

(iii) Our nearest star, other than the Sun, is 4.26 light years away. What is a light year?

[2]

(d) State **one** use for the artificial satellites that orbit the Earth.

[1]

THIS IS THE END OF THE QUESTION PAPER



DO NOT WRITE ON THIS PAGE

For Examiner's use only	
Question Number	Marks
1	
2	
3	
4	
5	

Total Marks	
--------------------	--

Examiner Number

Permission to reproduce all copyright material has been applied for.
In some cases, efforts to contact copyright holders may have been unsuccessful and CCEA will be happy to rectify any omissions of acknowledgement in future if notified.

250500



24GPY2124